

## NOVASIM MR | F-35

...reaching maximum training quality

### HIGHLIGHTS

- Full-Immersion
- 360° Mixed Reality view
- Procedure training scenarios
- Full scale F-35 replica Cockpit

### FEATURES

- Fifth generation fighter specific Cockpit and Grip replica (F-35 like)
- Dynamic Control Loading
- High fidelity motion system
- Compatible with various Simulation Software
- Sophisticated F-35 Flight physics Model
- Latest MR Headset
- Instructor Station

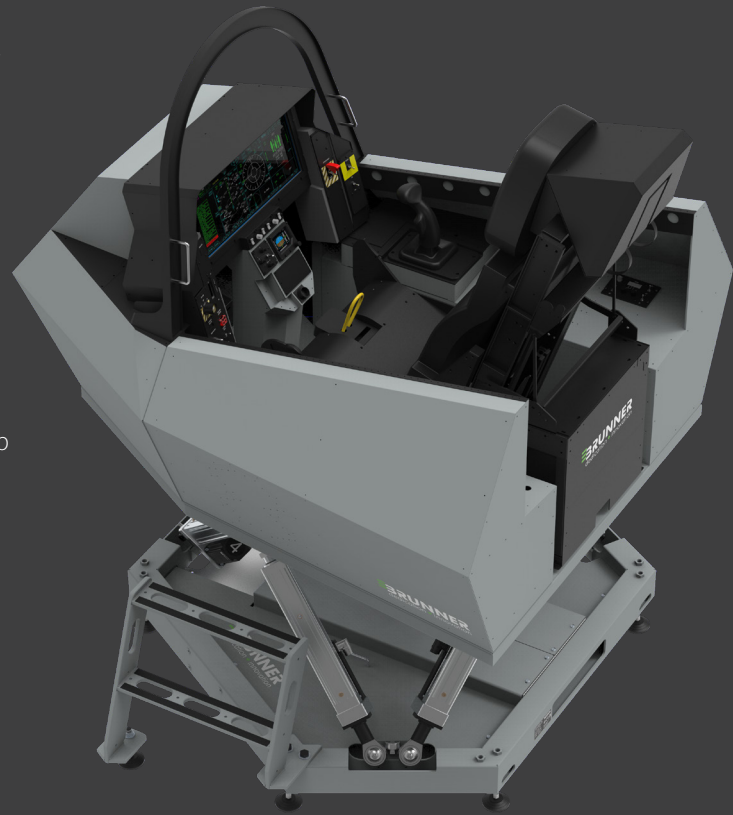

# NOVASIM MR | F-35.

## Mixed Reality Flight Simulator for professional Jet Pilot Training.

NOVASIM MR F-35 replicates the Lockheed Martin F-35 fighter Jet, while wearing a high resolution Mixed-Reality headset, the pilot interacts with real cockpit avionics and controls.

The MR technology seamlessly merges the real cockpit and the virtual 360° outside view in the headset to provide full immersion. In a Mixed Reality trainer, the authenticity of the replica cockpit is essential. From air-to-air refueling, formation flying to cockpit familiarization and hypoxia training the NOVASIM MR F-35 Simulator offers various procedure training scenarios.





**NOVASIM MR | F-35**  
...reaching maximum training quality



# NOVASIM MR | F-35.

## In a Nutshell.

The NovaSim MR F-35 is a compact and easy to install Flight Simulation Training Device that offers Mixed-Reality Technology to provide the highest possible training value.

The Novasim MR F-35 is suitable for all types and levels of pilot training. Learning the basics of Fighter Jet aviation, expanding cockpit experience or even strengthen skills in Hypoxia procedure training. Part task training like Air to Air refueling, formation flying etc. complete the various possible scenarios.

## Features.

- NOVASIM MR F-35 combines State-of-the-Art Mixed Reality technologies with powerful dynamic motion enriched Virtual Training environments
- BRUNNER MR technologies and motion compensation algorithm with highly advanced and latency-free motion cueing algorithms to generate full immersion and best training value
- A fully integrated solution, with power electronics and controls seamlessly integrated into the base-frame, following BRUNNER's Plug-and-Play approach
- Easy and fast installation process, transportable
- Very compact footprint, versatile and affordable, with lowest life-cycle-costs

## Operational Setup.



## Dimensions.

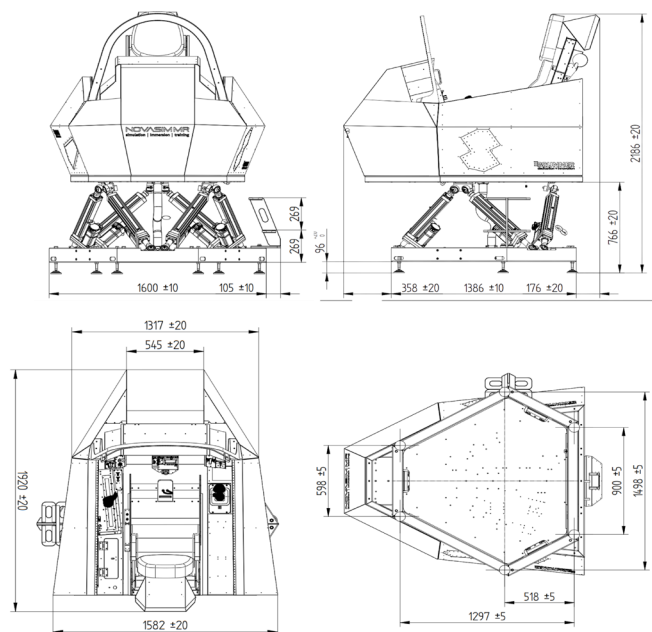

Powered by: **VARIQ**